

ScanMin SMASH Analyser

(Coal: Sulphur, Moisture, Ash, CV)

The ScanMin SMASH™ is a Prompt Gamma Neutron Activation Analysis (PGNAA) Elemental Analyser. The analyser uses a high-energy Am241Be radionuclide neutron source, which irradiates ALL the material on the belt as result of the temporary excitation of the atoms in the material This provide opportunity to measure two physical reactions:

1. Neutron Inelastic Scatter (NIS)
2. Thermal Neutron Capture. (TNS)

The source life is 432 years which ensures no source top up during the lifetime of the analyser. This dramatically reduces the OpEx costs. The ScanMin's patented double decker detector system measures the Gamma Rays emitted by the NIS and TNC reactions above and below the conveyor, compensating for any mass variation on the belt. Important Coal constituents to the thermal power and coal industries are measured directly by using the SMASH Analyser.

Each element will have a unique set of Gamma Ray spectrums for NIS and TNC. By selecting Regions of Interest (ROI) the ScanMin team can identify the Element and quantify its concentration.

The SMASH's design, high energy source and double detector system provides significant measurements and maintenance advantages.

Calibration Performance	Stable neutron source - No calibration adjustments due to source top up or source replacement. Variable mass flow compensation. Unaffected by Mass variation on the Belt. Measure ORGANIC & IN-ORGANIC elements.
Maintenance	Few moving parts. No Wear Parts. No Chilling or Cooling and associated consumables such as Nitrogen. Digital Temperature Controlled Electronics.
Safety	Automatic source drive control , retracts the source to Safe Space on shutdown. Shielding makes analyser safe for personnel in close proximity. Approved in Canada, Western Australia, South Africa
Source Life	432 Year Half-life. No source top up required for the entirety of the installation.
Design	Rugged design and wear resistant. Futureproof product.

Technology

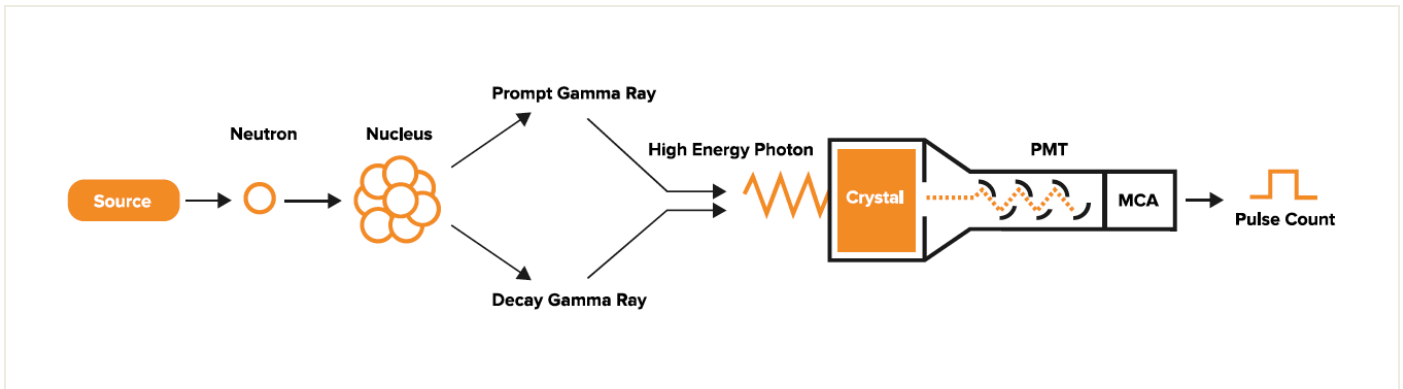

The ScanMin Minalyser™ analyser has the ability to analyse the bulk material on a conveyor belt. It is a rugged design that can operate in most industrial environments. The analyser can be used in a wide range of applications.

Real-time results assist operators and plant managers with active process control, quality control and contractual compliance.

Certification & SAHPRA

- Import
- Export
- Manufacturing

Western Australia and Canada



Dust Ignition Proof Marking
Certificate history: Ex tb IIIB T85°C Db IP 65

Applications

- Elemental concentration
- Mineralogy identification
- Total moisture
- Volatile matter
- ROM feed grade
- Stockpile blending control
- Mineralogy identification
- Quality assurance
- Contractual compliance
- Smelter feed
- C,H,N and O

Coal industries

(Using SMASH analysis and calibration software)

- Determination of quality by reporting
 - Ash
 - CV
 - Total moisture
 - Volatile matter
 - C, H, N and O
 - Other ash elements
- Coal processing
 - Quality control
 - Blending
 - Contractual compliance
- Coal fired power plants
 - Stockpile management
 - Boiler optimisation
 - Energy calculation
 - Emissions management

CONTACT US

Office phone:
+27 (0) 11 472-3000

Office fax:
+27 (0) 11 472-6787

Web:
www.scanmin.io

Albert Heydenrych :
albert@scanmin.co.za | +27 (0) 82 775 3950

Mahendra Gangai:
mahendra@scanmin.co.za | +27 (0) 72 491 9974

General email:
info@scanmin.co.za



ONLINE PROCESS CONTROL SOLUTIONS